



ROMANSTONE®

INTERLOCKING PAVING STONES

PLAZASTONE



* AVAILABLE IN 12" x 12" ONLY.
 ** AVAILABLE IN 6" x 6" ONLY.

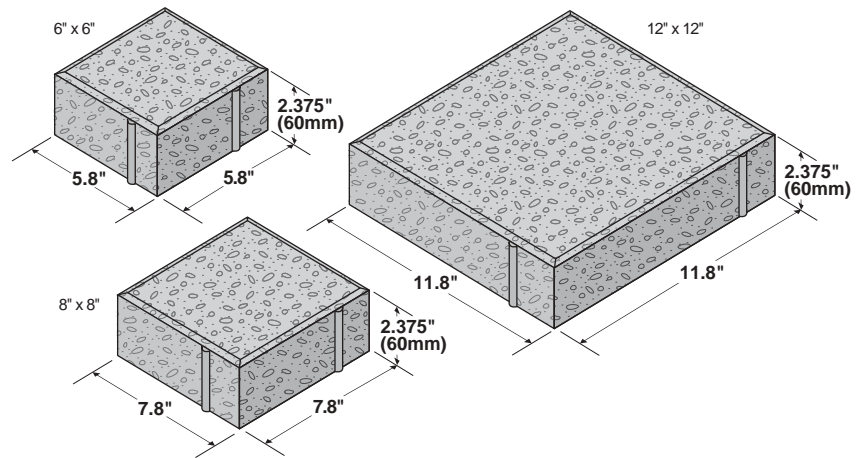

SIZE	UNITS/SQ. FT.	SQ. FT. PALLET/STRAP	UNITS PALLET/STRAP	WEIGHT/PALLET
5.8" x 5.8" x 2.375" (60MM)	4.25	105/13.1	432/54	2,730 LBS
7.8" x 7.8" x 2.375" (60MM)	2.35	127/21.1	300/50	2,900 LBS
11.8" x 11.8" x 2.375" (60MM)	1.03	120/30	120/30	3,120 LBS

The customizing possibilities of Plazastone render it the most desirable paving product available. Its collection of various sizes makes possible an extensive array of pattern configurations. Premium aggregates are carefully chosen creating beautifully textured pavers with distinctively vivid colorings.

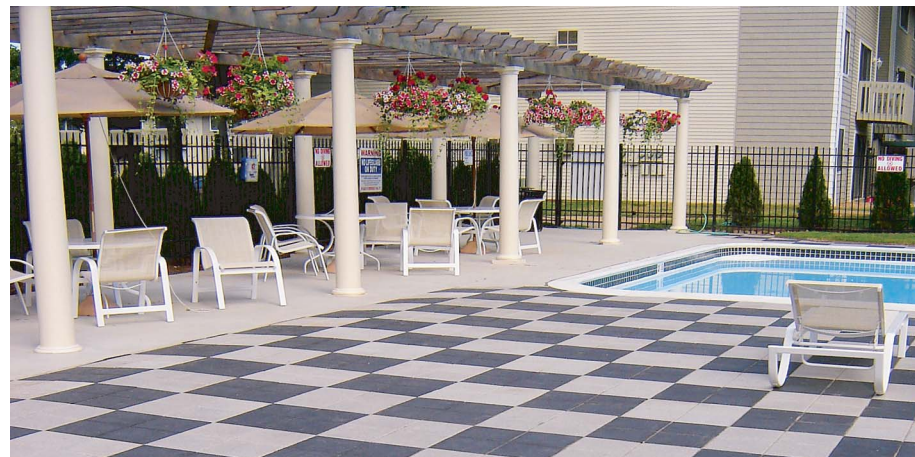

Contrasting colors make this simple pattern really shine.

SPECIFICATIONS

Plazastone is produced using a “no-slump” concrete mix, made under extreme pressure and high frequency vibrations. Unit pavers will meet or exceed the requirements established in the ASTM C936 (standard specification for interlocking concrete paving units). Requirements of this standard include an average compressive strength of 8,000 psi, average absorption no greater than 5%.

LAYING PATTERNS

PATTERN A
50% 6x6
50% 12x12

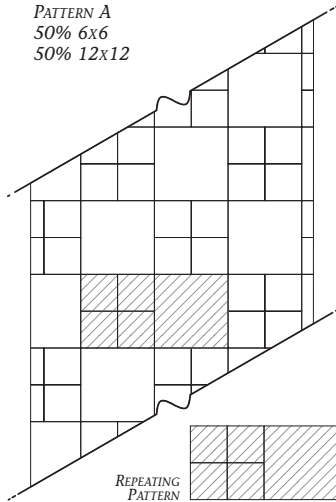

PATTERN B
100% 6x6
OR
100% 12x12

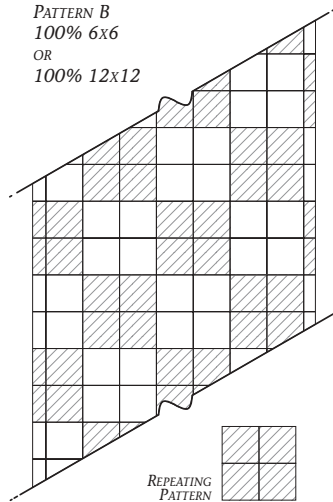

PATTERN C
30% 8x8
70% 12x12

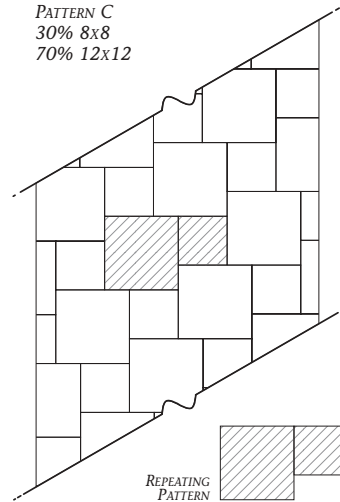

PATTERN D
33% 6x6
67% 12x12

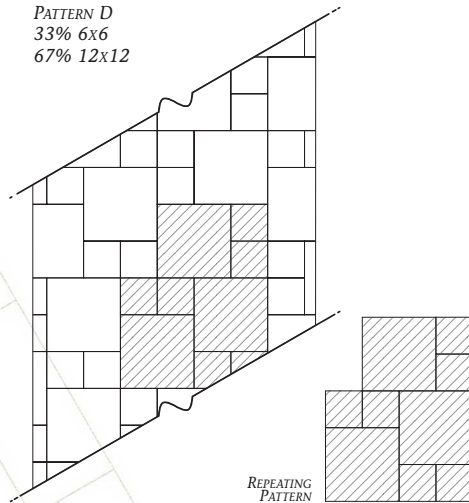

Proudly Distributed by:



www.romanstone.com



For ICPI Technical Notes
visit www.romanstone.com